

Optimized Realization of Software Components with Flexible OpenCL Functionality

Gabriel Campeanu, Jan Carlson and Séverine Sentilles

Mälardalen Real-Time Research Center, Mälardalen University, Västerås, Sweden

Email: {gabriel.campeanu, jan.carlson, severine.sentilles}@mdh.se

Keywords: software component, flexible component, GPU, embedded system, CBD, component-based development, component model, OpenCL

Abstract: Today, the newly available embedded boards with GPUs provide a solution to satisfy the ever-increasing requirements of modern embedded systems. Component-based development is a well-known paradigm used to develop embedded systems. However, this paradigm lacks GPU support to address the specifics of these new boards. This leads to components that typically have reduced reusability, poor maintainability and portability. One way to tackle the existing shortcomings is through *flexible components*, i.e., platform-agnostic components that, at design time, offer the possibility to be executed either on CPU or GPU. The current realization of flexible components, i.e., as regular components with functionality tailored for the selected hardware, introduces additional overheads such as component communication overhead. In order to tackle the introduced overheads, our solution groups connected flexible components under a *flexible group* that conceptually behaves as a component. We introduce an algorithm to identify the existing groups in a given component-based system and the generation rules that automatically realizes groups as regular components. To evaluate the feasibility of the new concept, the flexible group is implemented using a state-of-the-practice component model (i.e., Rubus) and examined through the vision system of an underwater robot.

1 Introduction

Modern embedded systems need to process huge amount of data originated from the interaction with the environment. For example, the autonomous Google car¹ receives from the vehicle's sensors (e.g., LIDAR, radar, camera) around of 750 MB of data per second. This data needs to be processed with a sufficient performance in order for the system to respond in real-time to the environment changes such as moving pedestrians.

The traditional (CPU-based) embedded systems have challenges in providing high performance when processing huge amount of data. This is due to various issues such as limited computational resources and the sequential execution model of the CPU. One of the existing solution comes from the usage of the boards with Graphics Processing Units (GPUs). Specifically developed with a parallel execution model, the GPU delivers an improved performance compared to CPU, in the context of highly-parallel applications such as molecular mechanics simulations (Stone et al., 2007). OpenCL² is a programming model supported by most of the existing

embedded boards with GPUs, that allows development of functionality for both CPU and GPU.

In this work, we use component-based development (CBD) to construct embedded systems. This methodology promotes the development of applications through the composition of existing software blocks known as (software) components. The adoption of CBD in industry was successfully accomplished through several component models such as AUTOSAR³, Rubus (Hänninen et al., 2008) and IEC 611-31 (John and Tiegelkamp, 2010).

However, when it comes to the component-based development of embedded systems with GPUs, the existing component models provide no GPU support. Therefore, the component developer needs to encapsulate all the GPU-related information inside the component, which leads to several problems such as reduced reusability and poor maintenance (Campeanu et al., 2017). For example, by encapsulating the number of GPU threads used, the component is reusable only on platforms that have resources to fulfill the component requirements.

To address these problems, we introduced in our previous work the so-called *flexible components* equipped with OpenCL functionality (Campeanu

¹<https://waymo.com>

²<https://www.khronos.org/opencl/>

³<https://www.autosar.org>

et al., 2017). This type of component has a “flexible” behavior at the design time, that is, the system designer can choose where to execute the component, either on CPU or GPU. When the design is completed, the flexible component is automatically realized as a regular component compliant with the underlying component model and with its functionality tailored for the selected hardware. However, when several flexible components that are allocated on the same device (i.e., CPU or GPU) are connected, unnecessary overhead appears due to the following points:

- Each flexible component is realized as a component that encapsulates, besides functionality, required OpenCL device-environment to address the hardware. The individual device-environments encapsulated by the components are identical and have the same purpose, i.e., accessing the same allocated device.
- The way that the functionalities of flexible components communicate, being encapsulated inside regular components, needs to comply with the component model regulations. Hence, instead of being achieved directly between functionalities, data is exchanged through the interfaces of the corresponding connected components, i.e., at the component-level.

We propose a solution to tackle the unnecessary overheads by identifying groups of connected flexible components with the same hardware allocation. Conceptually behaving as a single component, a *flexible group* is realized as a regular component. The advantages of the flexible group are the following:

- The realized (group) component encapsulates a single OpenCL device-environment to access the allocated hardware. All the functionalities of the grouped components are executed through the same device-environment.
- The communication between the functionalities of the grouped components is done inside of the realized (group) component. Therefore, data is passed directly between the functionalities, i.e., at the functionality-level, avoiding the overhead of component interface communication. Moreover, this way of realizing the communication inside the flexible group, does not break the (flexible) components encapsulation.

The realization of flexible groups as regular components is implemented using a state-of-the-practice component model (i.e., Rubus) and evaluated using the vision system of an underwater robot.

The remainder of the work is divided as follows. Background is covered by Section 2. The definition of the flexible group is described in Section 3, and

its realization in Section 4. The evaluation is covered by Section 5, followed by related work (Section 6) and conclusions (Section 7).

2 Background

The section is divided in three parts describing the context of: *i*) component-based development in embedded systems, *ii*) GPUs and OpenCL environment, and *iii*) flexible components.

2.1 Component-based development in embedded systems

Component-based development is a software engineering paradigm that promotes the construction of systems through the composition of existing software units called software components. A key concept of CBD is the *encapsulation* principle where all the information are encapsulated inside a component, hidden from anything outside it. The only way to access a component information is through the component *interface*. In this work, we deal with port-based interface, where a *port* is a component access point and the interface encloses all the component (input and output) ports.

The rules to construct components are given by a *component model*. There exist many component models, both from academia, e.g., ProCom (Sentilles et al., 2008), and industry, e.g., AUTOSAR⁴ and Rubus (Hänninen et al., 2008). The component model also introduce the way that components interact. Based on the domain that the component models are utilized in, different communication styles are used (Crnkovic et al., 2011). For example, AUTOSAR uses the *request-response* and *sender-receiver* interaction styles in the automotive industry. The interaction style used in our work is the *pipe-and-filter* style used by e.g., Rubus and IEC 611-31. In this particular interaction style, the component are seen as *filters* while the communication links are *pipes*. The pipe-and-filter style is suitable for streaming of event-type of real-time and embedded applications, due to the straightforward mapping between the control application flow and the required control specifications of the domain.

As we realize our solution using Rubus, we provide more details about this particular component model. A Rubus component, called *software circuit*, is equipped with two types of ports, i.e., trigger and data ports. A Rubus component has one input and

⁴<https://www.autosar.org>

one output trigger ports, and one or many (input/output) data ports. Through the trigger port, the control is passed between component; the data ports communicate (send/receive) data.

A Rubus component follows the Read-Execute-Write execution model. Initially in an idle state, a component is activated when its input trigger port receives the control (i.e., is triggered). The component starts by Reading the data from all its input data ports, followed by the Execution of the functionality using the input data. The results are Written in the output data ports, after which, the output trigger port is activated and passes the control to the connected component(s). After passing the control, the component re-enters the idle state.

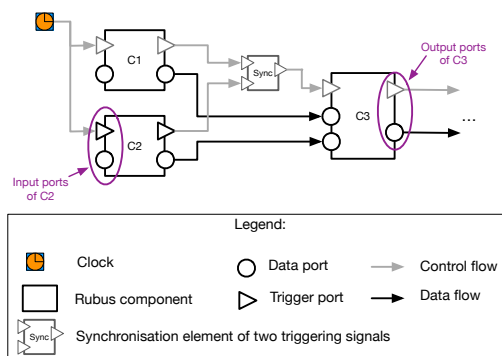

Figure 1: Three Rubus connected components

Figure 1 presents three connected Rubus components, where $C1$ and $C2$ components are triggered by the same clock element. After the execution of the two components, the control is passed to $C3$ through a synchronization element. The synchronization element, similar to a logic gate, operates using different logic functions, such as AND and OR.

2.2 GPUs and OpenCL

Nowadays, many programming models are used to access the GPU hardware and develop functionality. The two most used are CUDA⁵ and OpenCL⁶. The CUDA programming model is developed by NVIDIA to specifically address their GPU platforms. OpenCL is a programming model that addresses various number of processing unit such as m-CPUs, GPUs, FPGAs and DSPs. Being supported by most of the existing embedded platforms, OpenCL is used in this work to construct the proposed solution.

The OpenCL model visualizes the hardware platform as being composed of a host (i.e., CPU) and one

⁵<http://docs.nvidia.com/cuda/cuda-c-programming-guide/index.html>

⁶<https://www.khronos.org/opencl/>

or several devices (e.g., CPU, GPU). The host, also known as the system's brain, is the one that triggers all commands executed by the device(s). Several interconnected steps are required to develop functionality using the OpenCL model, as follows. 1) A *platform* with the installed vendor's driver, needs to be defined; it contains a *context* and a *command-queue*. The context is an environment that contains a number of selected devices; through the command-queue, all the commands of the host are sent to the devices enclosed by the context. 2) The functionality (i.e., one or several *kernel* functions) that will be executed on the device(s) contained by the *context*, is enclosed in a *program* object and compiled to construct a dynamic library. 3) Memory buffers need to be allocated on the device, in order to e.g., hold the processed data. 4) The kernel function(s), i.e., the functionality of the application, need to be constructed. 5) Commands to execute the defined kernels are submitted to the command-queue. Before executing the kernels, specific settings need to be defined, e.g., the number of used device threads. After the functionality is executed, the results are copied back to the host. In the end, the allocated resources (i.e., memory buffers, program, context, command queue, kernels) are released.

2.3 Flexible components

A flexible component is a type of component that exists at the design time, where the system designer can select the processing unit to execute it, i.e., either on CPU or GPU. A flexible component C has a functionality F^C that is accessed through an interface I^C . There are two types of data ports enclosed in the interface, i.e., regular and multi-element ports. Regular ports support regular data types, such as *integer* and *double*. The multi-element ports support an introduced multi-element type (i.e., *m-elem* type) used to describe large data (e.g., 2D images). A multi-element port is characterized by several information to describe its data: *i) width* to describe the horizontal size, *ii) height* to specify the vertical size, and *iii) size* to denote the size of each data element. For example, a color 2D image has a width of 256 pixels, a height of 512 pixels, where each RGB pixel has a size of 3. Furthermore, any (regular and m-elem) data port is characterized by a *type* information and unique *name*.

The interface I^C of a flexible component is composed of two subsets, i.e., I_{in}^C and I_{out}^C for input and output ports, respectively. Furthermore, each subset is divided according to the data types of the ports. For example, I_{in}^C contains $I_{reg.in}^C$ for all the input ports of regular types, $I_{multi.in}^C$ for all input ports of m-elem

type and the input trigger port $p_{\text{trigg.in}}^C$.

After the system designer decides the hardware allocation of the flexible components, an automatic realization converts them in regular components (Campeanu et al., 2017). All the necessary code corresponding to the component interface, constructor, behavior function and destructor, is automatically generated. Furthermore, the wiring between all the initial connections of the flexible component's ports, are automatically accomplished to connect the ports of the generated interface. The functionality of the flexible component is included in the generated component code, adjusted to be executed on the selected hardware (i.e., CPU or GPU). Therefore, a suitable OpenCL device-environment is automatically encapsulated inside the component, in order to access the allocated hardware.

3 Flexible groups

The usage of flexible components is an existing solution proposed by Campeanu et al. in (Campeanu et al., 2017) to provide support for component-based development of modern embedded systems with GPUs. The existing solution realizes flexible components as regular components, which introduces several overheads. In order to reduce these overheads, we propose to group connected flexible components with the same hardware allocation, into what we call a *flexible group*. The flexible group is realized as a component that has the same allocation as the enclosed components.

Our solution is described through a simple example illustrated in Figure 2, where a flexible group encloses two flexible components. Initially, Figure 2(a) presents two flexible components that communicate. After realization, each flexible component (realized as a regular component) encapsulates its own device-environment through which it executes the functionality. The communication between the components functionalities is done at the component-level, through the components port-based interfaces.

Assuming that C_1 and C_2 are allocated on the same hardware, using our approach, a flexible group G is identified, containing C_1 and C_2 (i.e., Figure 2(b)). In our vision, G contains one OpenCL device-environment through which, the enclosed functionalities are executed. Furthermore, the communication (i.e., data and control flow) between C_1 and C_2 is done at the functionality level, i.e., directly between F^{C1} and F^{C2} , by providing the output of F^{C1} as input of F^{C2} . Moreover, encapsulating F^{C1} and F^{C2} in G does not break the encapsulation of C_1 and C_2 .

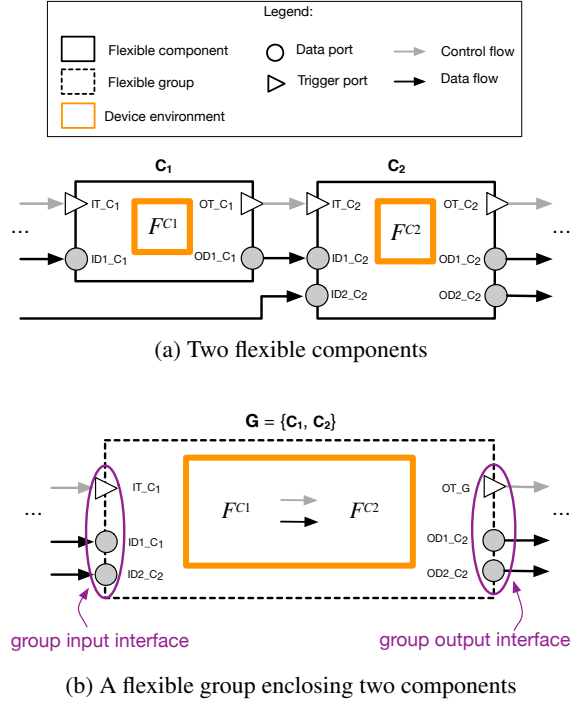

Figure 2: The transition from flexible components to flexible group

The group inherits the input and output ports of the enclosed components, that communicate with anything outside the group. Therefore, the group input interface contains two input data ports, i.e., $ID1_{C1}$ from C_1 and $ID2_{C2}$ from C_2 , since these two ports receive data from outside the group. The group output interface has $OD1_{C2}$ and $OD2_{C2}$ data ports, both inherited from C_2 . Furthermore, the group is equipped with one input and one output trigger ports.

The remaining of the section presents the definition of the flexible group and the algorithm that identifies groups in a given component-based system.

3.1 Group definition

We define a flexible group G as an ordered set of connected flexible components that have the same hardware allocation. The order of the components enclosed in the set, determines their execution pattern:

$$G = \{C_1, C_2, \dots\}, \text{ where,} \\ \text{alloc}(G) = \text{alloc}(C_k), \text{ and} \\ C_{k-1} \text{ executes before } C_k$$

The functionality of a flexible group is accessed through the port-based group interface. The interface I^G is constructed from all the ports of the grouped components that communicate with anything outside

the group, as follows. An input port of the group is defined as an input port of any of enclosed components, that receives information from a component that is outside of the group. Similarly, an output port of any enclosed component that sends data to external component(s) is considered an output port of the group.

$$I^G = \{p_1, p_2, \dots\}, \text{ where } p_m \in I^{C_1} \cup I^{C_2} \cup \dots$$

The group interface is divided in two elements: *i*) one for the input ports of the group, i.e., I_{in}^G , and *ii*) the other enclosing the output group ports, i.e., I_{out}^G . Furthermore, each (input and output) interface is divided in subsets according to the enclosed data types of the ports. For example, the group input interface I_{in}^G contains regular ports ($I_{reg.in}^G$), multi-element ports ($I_{multi.in}^G$) and the input trigger port ($p_{trigg.in}^G$).

$$I^G = I_{in}^G \cup I_{out}^G, \text{ where}$$

$$I_{in}^G = I_{reg.in}^G \cup I_{multi.in}^G \cup \{p_{trigg.in}^G\} \text{ and}$$

$$I_{out}^G = I_{reg.out}^G \cup I_{multi.out}^G \cup \{p_{trigg.out}^G\}$$

3.2 Group identification

This section presents the algorithm that identifies the flexible groups in a given component-based system. We see the system as a directed graph, where each component is a node and the trigger port connection between two components is a directed vertex. In this context, identifying the groups is similar to a depth-first search algorithm.

The algorithm, described in Algorithm 1, starts by initializing the main variables. For instance, Γ , representing a set containing all identified groups in the system, is initially an empty set. In Rubus, the clock elements are the system elements that initiate component triggering. Therefore, the algorithm starts traversing the system from the clock elements, by calling the main loop (i.e., the *Top* function) for each triggered clock component. Initially, when starting to traverse the system and there is no formed group, for each encountered and not visited flexible component, a new flexible group with the same hardware allocation is created. The component is added to the created group and the group is added to Γ . The *Top* function is recursively executed for all of the component's triggering elements (e.g., regular component, flexible component). In order to include all connected flexible components (with the same hardware allocation) in the same group, we use a reference to the current group set. This reference is passed to the loop function as a parameter. Whenever a triggered flexible component has a different allocation than the refer-

```

1  $\Gamma \leftarrow \emptyset$ 
2  $Visited \leftarrow \emptyset$ 
3 foreach clock  $C$  in the system do
4   |  $Top(C, NULL)$ 
5 end
6  $Top(C, G)$ :
7 if  $C \notin Visited$  then
8   |  $add(C, Visited)$ 
9   | if  $flexible(C)$  then
10    | if  $G = NULL \vee alloc(C) \neq alloc(G)$ 
11     | then
12     |    $G \leftarrow createNewGroup()$ 
13     |    $alloc(G) \leftarrow alloc(C)$ 
14     |    $add(G, \Gamma)$ 
15     | end
16     |  $add(C, G)$ 
17   | end
18   | else
19   |    $G \leftarrow NULL$ 
20   | end
21   | foreach triggering edge  $C \rightarrow C'$  do
22     |  $Top(C', G)$ 
23   | end

```

Algorithm 1: Identifying flexible groups

ence group, a new group is created and becomes the current reference group.

4 Group realization

The flexible group is realized following the characteristics of a regular component generation, i.e., through an *interface*, *constructor*, *behavior function* and *destructor*, as follows. The generated interface contains all the (input and output) data ports of the group. The constructor generation initializes the resource requirements of the group, e.g., allocates memory space to hold the results from all enclosed components. The group behavior executes the functionalities of the grouped components. The destructor releases the group allocated resources.

Furthermore, we re-wire the connections between the group (input and output) interface and the interfaces of (outside-the-group) components that were initially connected to the group enclosed components.

4.1 Code generation

Using the existing way that Rubus defines the interface of a regular component, we generate the *group interface* in a similar manner, as presented in Listing 1. The *SWC_Group_iArgs* interface is defined as a structure (lines 35-38) with two elements corresponding to the output and input interfaces. The output interface *OP_SWC_iArgs* is constructed as a structure (lines 28-32), where the elements are the data ports of the group output interface I_{out}^G . Similarly, *IP_SWC_iArgs* is a structure that encloses the data ports of the group input interface I_{in}^G .

Besides input data ports, *IP_SWC_iArgs* interface contains the so-called *configuration* ports. Each flexible component is equipped with a configuration interface. Through it, the system designer provides appropriate settings regarding the number of device threads used to execute the functionality. For example, a flexible component allocated on GPU could receive, through the configuration interface, settings to use 2048 GPU threads. In the flexible component realization, the configuration interface is generated as regular input data port in order to not introduce additional Rubus framework elements. In our generation, we use the same rational, i.e., the flexible group is equipped with a configuration interface generated as an input data port, for each enclosed component (line 22).

The settings received through the configuration interface are inserted in the *GPU_settings* structure. The first four elements (lines 5-8) refers to the number of device-threads used by the functionality, while the rest of the elements (lines 9-11) are settings related to the environment, such as the *command_queue* mechanism.

Listing 1: Interface code

```

1  /* device-settings for each flexible component C */
2  <counter = 1>
3  <foreach C in G>
4  typedef struct {
5      int blockDim_x;
6      int blockDim_y;
7      int gridDim_x;
8      int gridDim_y;
9      cl_context context;
10     cl_command_queue cmd_queue;
11     cl_device_id device_id;
12 }settings<counter+=1>;
13 <endforeach>
14
15 /* the group input ports */
16 <counter = 1>
17 typedef struct {
18 <foreach p in  $I_{in}^G$ >
19     <p.type> *<p.name>;
20 <endforeach>
21 <foreach C in G>
22     settings<counter> *cfg<counter>;
23 <counter += 1>
24 <endforeach>
25 }IP_SWC_iArgs;
26
27 /* the group output ports */

```

```

28 typedef struct {
29 <foreach p in  $I_{out}^G$ >
30     <p.type> <p.name>;
31 <endforeach>
32 }OP_SWC_iArgs;
33
34 /* the interface of the group */
35 typedef struct {
36     IP_SWC_iArgs IP;
37     OP_SWC_iArgs *OP;
38 }SWC_Group_iArgs;

```

The *constructor*, illustrated in Listing 2, encloses all the information regarding the group initialization, as follows. The listing starts by allocating memory for each flexible component from the group. That data received by a component through the input ports is the input data for the functionality, while the functionality outcomes are sent through the output ports. Therefore, corresponding to each output data port, we allocate memory to hold the functionality results. Due to the specifics of the OpenCL, a kernel function must store a regular output value (e.g., integer value) in a one-value memory buffer. Thus, we allocate one-value memory buffers for regular output ports (line 4). For data of m-elem type, the memory buffer is allocated with an appropriate size (line 8). Moreover, in line 15, the multi-element ports that are considered output ports of the group are linked to the corresponding memory locations. This is done because these ports will be wired to outside-of-the-group ports, and the system communication will be accomplished by using the values of the connected ports.

The core part of the constructor defines the group functionality. A string variable encloses the functionalities of the grouped components, i.e., the kernel function name (line 21), the arguments (lines 23, 26, 29 and 32) that correspond to the input and output component ports, and the component functionality (line 37). The string variable is loaded into a program object (line 43) and then compiled to create a dynamic library (line 46). In the last part of the constructor, kernel objects are constructed for all flexible components (line 51), alongside with the individual settings regarding the number of used device-threads (line 54 and 55). We mention that these settings are provided by the system designer, using the configuration interface port.

The reason to include the group functionality inside the constructor is to create the dynamic library once (i.e., by creating and compiling the *program* object), at the system initialization stage.

Listing 2: Constructor code

```

1  /* create memory buffers for each flexible component
   that is part of a flexible group */
2  <foreach C in G>
3  <foreach p in  $I_{reg,out}^C$ >
4      void *result<p.name> = apiCreateBuffer(settings->context,
5      CL_MEM_WRITE_ONLY, sizeof(<p.type>),NULL,NULL);
6  <endforeach>

```

```

6
7 <foreach p in  $I_C^{multi\_out}$ >
8 void *result_<p.name> = apiCreateBuffer(settings->context,
    CL_MEM_WRITE_ONLY, <p.width*p.height*p.size>,NULL,
    NULL);
9 <endforeach>
10 <endforeach>
11
12 /* connect the output ports of the group with the
    created memory buffers */
13 <foreach C in G>
14 <foreach p in  $I_{out}^G$ >
15 <p.name>->data = (unsigned char*) result_<p.name>;
16 <endforeach>
17
18 const char *source_string = "
19 <counter_kernel = 1>
20 <foreach C in G>
21 __kernel void flexible_kernel<counter_kernel> (
22 <foreach p in  $I_{reg\_in}^C$ >
23 <p.type> <p.name>,
24 <endforeach>
25 <foreach p in  $I_{reg\_out}^C$ >
26 __global <p.type> *result_<p.name>,
27 <endforeach>
28 <foreach p in  $I_{multi\_in}^C$ >
29 __global <p.type> *<p.name>,
30 <endforeach>
31 <foreach p in  $I_{multi\_out}^C$ >
32 __global unsigned char *result_<p.name>,
33 <endforeach>
34 ){
35
36 /* flexible component functionality */
37 <FC>
38 };
39 <counter_kernel += 1>
40 <endforeach>
41
42 /* Create a program from the kernel sources */
43 cl_program program = clCreateProgramWithSource(settings->
    context, 1, (const char **)&source_string, NULL, NULL);
44
45 /* Build the program */
46 clBuildProgram(program,1,&(settings->device_id), NULL, NULL,
    NULL);
47
48 <counter_kernel=1>
49 <foreach C in G>
50 /* Create the kernel object */
51 cl_kernel kernel<counter_kernel> = clCreateKernel(program, "
    flexible_kernel<counter+=1>", NULL);
52
53 /* individual settings - device threads usage */
54 int total_thrd<counter_kernel>[2] = {(settings->gridDim_x), (
    settings->gridDim_y)};
55 int group_thrd<counter_kernel>[2] = {(settings->blockDim_x),
    (settings->blockDim_y)};
56 <counter_kernel+= 1>
57 <endforeach>

```

The execution of the group functionality is enclosed in the *behavior function* (Listing 3) which is performed every time the group is activated. To execute the functionality using the OpenCL model, the host needs to send to the selected device (i.e., CPU or GPU), the execution command of the desired kernel function. However, before triggering the execution, the input data and locations for output results need to be specified. Hence, the first part of the behavior function handles the parameters (i.e., provide the values) of the group enclosed kernels. Basically, the parameters of a kernel are the input data and output data location of the corresponding flexible component. For the input ports of the enclosed components that are not considered the group ports, we provide the values received from the connected ports. This

is done by directly providing the allocated memory location corresponding to the connected ports (lines 11 and 25). In this way, the communication between kernel functions of different connected components is directly realized inside the group, at the functionality level.

For (regular and multi-element) output ports, we provide the data existing in the corresponding allocated memory (lines 16 and 31). Based on the order of the grouped set, the functionalities (i.e., the *kernel* objects) of the enclosed components are triggered to be executed on the selected hardware (line 39). In the last part, we copy the computed one-value of the allocated memory buffers, to the corresponding regular data output ports of the group (line 49). When the wiring between existing system components and groups will be done, the regular output ports of the group will provide a regular data (e.g., integer value) instead of a (one-value) memory buffer (i.e., pointer). In this way, the Rubus rules that realizes communication between data ports are not interfered.

Listing 3: Behavior function

```

1 /*Set the kernel arguments of each enclosed component*/
2 <counter_kernel = 1>
3 <counter_arg = 0>
4 <foreach C in G>
5 <for each p in  $I_{reg\_in}^C$ >
6 /* for regular input ports of flexible components that
    are considered input ports of the group */
7 <if (p in  $I_{reg\_in}^G$ )>
8 apiSetKernelArg(kernel<counter_kernel>, <counter_arg+=
    1>, sizeof(<p.type>), (void*)&<p.name>);
9 /* for regular input ports of flexible components that
    are not input ports of the group */
10 <else>
11 apiSetKernelArg(kernel<counter_kernel>, <counter_arg+=
    1>, sizeof(<p.type>), (void*)&result_<p.name>);
12 <endif>
13 <counter_kernel+= 1>
14 <endforeach>
15 <for each p in  $I_{reg\_out}^C$ >
16 apiSetKernelArg(kernel<counter_kernel>, <counter_arg>,
    sizeof(<p.type>), (void*)&result_<p.name>);
17 <counter+= 1>
18 <endforeach>
19 <foreach p in  $I_{multi\_in}^C$ >
20 /* multi-element input ports of flexible components
    that are input ports of the group */
21 <if (p in  $I_{reg\_in}^G$ )>
22 apiSetKernelArg(kernel<counter_kernel>, <counter_arg>,
    <p.width*p.height*p.size>, (void*)&<p.name>);
23 /* multi-element input ports of flexible components
    that are not input ports of the group */
24 <else>
25 apiSetKernelArg(kernel<counter_kernel>, <counter_arg>,
    <p.width*p.height*p.size>, (void*)&result_
    <p.name>);
26 <endif>
27
28 <counter+= 1>
29 <endforeach>
30 <for each p in  $I_{multi\_out}^C$ >
31 apiSetKernelArg(kernel<counter_kernel>, <counter_arg>,
    <p.width*p.height*p.size>, (void*)&result_
    <p.name>);
32 <endforeach>
33 <counter_kernel+=1>
34 <endforeach>
35
36 /* Execute the OpenCL kernels of the flexible
    components */
37 <counter=1>
38 <foreach C in G>

```

```

39     clEnqueueNDRangeKernel(settings->cmd_queue, kernel<counter>,
40         2, NULL, total_thrd<counter>, group_thrd<counter>, 0,
41         NULL, NULL);
42     <counter+=1>
43 <endforeach>
44 /* Wait for command queue and device to finish their
45    activities */
46     clFlush(settings->cmd_queue);
47     clFinish(settings->cmd_queue);
48 /* copy the regular output(s) to the corresponding
49    regular output port(s) of the group */
50 <foreach C in G>
51     <foreach p in Ireg-outC>
52     apiEnqueueReadBuffer(settings->cmd_queue, result_<p.name>,
53         CL_TRUE, 0, sizeof(<p.type>), &<p.name>, 0, NULL,
54         NULL);
55     <endforeach>
56 <endforeach>

```

The *destructor* releases the resources allocated by the constructor. Basically, the kernel objects (line 4), the program object (line 7) and the allocated memory buffers (line 10) are released.

Listing 4: Destructor code

```

1  /* Clean up */
2  <counter_kernel = 1>
3  <foreach C in G>
4  clReleaseKernel(kernel<counter_kernel>);
5  <counter_kernel+=1>
6  <endforeach>
7  clReleaseProgram(program);
8  <foreach C in G>
9  <foreach p in ICout>
10     apiReleaseBuffer(result_<p.Name>);
11 <endforeach>
12 <endforeach>

```

4.2 Connection rewiring

The way that the Rubus framework generates the wiring between components needs to be partially changed by the fact that several grouped flexible components are generated as a single component. Inside the group, the rules that generate the wiring between the enclosed components are ignored because the data communication is accomplished at the functionality level instead, i.e., inside the generated behavior function of the group (Listing 3, lines 11 and 25). The connections between the group’s components and everything outside the group needs to be modified in the following way. Instead of generating the wiring between the interfaces of the outside-the-group components and the interfaces of the enclosed components, we re-wire the connections between the interfaces of the outside components and the group.

The trigger connection leading in to the group is handled in the same way as the data connections, but outgoing trigger connections should all be rewired to originate from the single output trigger port in the group interface.

Thus, when realizing a connection from port p_1 of component C_1 to port p_2 of component C_2 (i.e., where $p_1 \in I^{C_1}$ and $p_2 \in I^{C_2}$), three cases must be considered:

- If $\exists G : C_1 \in G \wedge C_2 \in G$, then no connection should be generated.
- If $\exists G : C_1 \notin G \wedge C_2 \in G$, then the connection should be generated to the realization of p_2 belonging to the group G (since there is no individual realization of component C_2).
- If $\exists G : C_1 \in G \wedge C_2 \notin G$, there are two sub cases:
 - If p_1 and p_2 are data ports, then the connection should be generated from the realization of p_1 belonging to the group G .
 - If p_1 and p_2 are trigger ports, then the connection should be generated from the realization of $p_{trigg-out}^G$ (the trigger output port of the group G).

Following the Rubus approach, the re-wiring is done at the system realization stage, before the system is actual executed. Therefore, there is no system execution overhead introduced by the re-wiring realization.

5 Evaluation

To evaluate our solution, we use as a case study the vision system of an underwater robot (Ahlberg et al., 2013). The robot autonomously navigates under water and fulfills various missions, such as tracking buoys. The hardware is composed of two cameras connected to an embedded board with GPU capabilities. Figure 3 describes the vision system architecture developed using the Rubus component model. The figure also illustrates the flow of the frames inside the system. Two camera components are connected to the physical sensors and convert the received raw data in readable frames which are forwarded to *MergeAndEnhance* component. After the initial frames are merged into a single frame and its noise removed, the *CovertGrayscale* converts it in grayscale format. Finally, the *EdgeDetection* component outputs a black-and-white frame where objects are delimited with white lines; based on this frame, *ObjectDetection* detects objects. The system contains two more components that compress the (color and grayscale) frames and provide them to the *Logger* which records the underwater journey. Due to the characteristics of their functionality (i.e., processing images), the system contains five flexible components (i.e., *MergeAndEnhance*, *CovertGrayscale*, *CompressRGB*, *CompressGrayscale* and *EdgeDetection*) that can be executed either on CPU or GPU.

Using the described vision system, we build five scenarios where the flexible components are differently allocated. Table 1 presents the constructed scenarios, where, e.g., all the flexible components are allocated

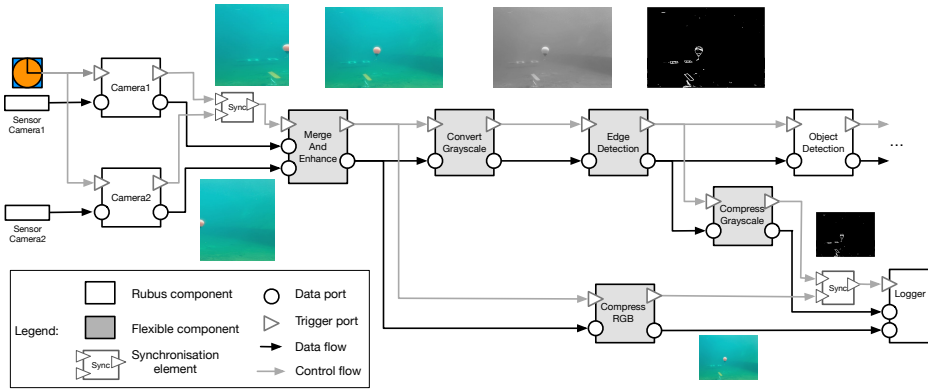

Figure 3: The Rubus vision system of an underwater robot

on GPU in Scenario 1. For each of the constructed scenarios, we implement two versions of the vision system, as follows. The naïve version uses the existing solution where each flexible component is realized as a regular component. The other version with our proposed solution, encloses flexible components in groups which are realized as regular components. To examine the impact of our solution, we compare the end-to-end execution times for both system versions, in each scenario. Moreover, we check the correctness of the output frames for the evaluated vision versions.

Table 1: Allocations scenarios for the vision system

Flexible Component	Hardware allocation scenario				
	1	2	3	4	5
MergeAnd Enhance	GPU	GPU	GPU	GPU	CPU
Convert Grayscale	GPU	GPU	GPU	CPU	CPU
Edge Detection	GPU	CPU	GPU	GPU	CPU
Compress RGB	GPU	GPU	CPU	CPU	CPU
Compress Grayscale	GPU	CPU	CPU	CPU	CPU

In each constructed scenario for the versions that use our solution, a number of groups are formed inside the system. For instance, there are two identified groups in Scenario 2, as illustrated in Figure 4. While *FlexibleGroup1* encloses the flexible components that are connected and allocated on GPU (i.e., *MergeAndEnhance*, *ConvertGrayscale* and *CompressRGB*), *FlexibleGroup2* is allocated on CPU and contains *EdgeDetection* and *CompressGrayscale*. The first group, being realized as a component, has two input ports cor-

responding to the *MergeAndEnhance* input ports; regarding the output ports, it inherits one from *ConvertGrayscale* and another from *CompressRGB*. Similarly, the second flexible group, after realization, inherits one input port from *ConvertGrayscale* and two output ports, one from *ConvertGrayscale* and the other from *CompressGrayscale*.

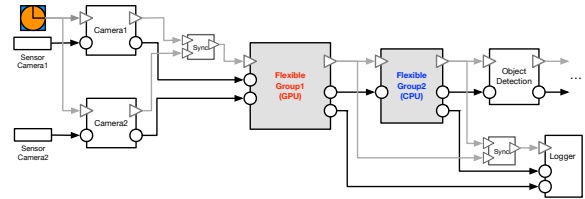

Figure 4: Realized flexible groups in Scenario 2

In each scenario, both system versions were executed 1000 times. We mention that, in each scenarios, we inspected the end-to-end execution times only for the system parts that have flexible functionality. For example, for the naïve version in Scenario 1, we measured the execution time from the beginning of the execution of *MergeAndEnhance* until *CompressGrayscale* and *CompressRGB* components finish their executions.

Table 2: Experimental results

Scenario	Number of groups	Execution time (ms)	
		Initial realization	Optimized realization
1	1	3.5	1.1
2	2	20.9	19.9
3	3	17.2	15.7
4	5	21.6	21.6
5	1	26.3	23.5

After we compared the outcomes of both system

versions, we concluded that the resulted frames of *CompressGrayscale* and *CompressRGB* functionalities were the same in both versions, for all five scenarios.

In addition to the correctness analysis, we examined the execution times of both system versions. The results of the experiments, presented in Table 2, show that our solution does not introduce any overhead regarding the system execution time. In Scenario 1, we notice a substantial improvement with our solution due to its improvements, i.e., having one device-environment for all five GPU-allocated functionalities and removing the communication overhead. As expected, in Scenario 4, the results of the two versions are the same. This is due to the fact that the naïve solution contains five components realized from five flexible components, and our solution version contains five components resulted from five flexible groups.

6 Related Work

A way to better manage the complexity of component-based systems is to use composite components. A composite component, composed of several flat components, follows the same rules (e.g., encapsulation) as regular components, and its functionality is given by the combination of enclosed components. To support analysis techniques for component-based systems, Lévêque et al. introduce a solution to flatten systems with composite components (Lévêque et al., 2011). Accordingly, the solution breaks a composite component into its constituent components, and realizes the (data and control) connections with the rest of the system. Other work that splits a composite component, is used in distributed systems, where the decomposed components are executed on different execution nodes (Radermacher et al., 2015). Our solution acts in the opposite direction in order to reduce system overhead. From a flat component-based system, we enclose connected components in groups and “compress” the groups in conceptual components.

The functionality of a flexible group is composed from the functionalities of the enclosed components (i.e., kernel functions). We execute the kernel functions in the order that the components are enclosed in the flexible group set. The performance of a system may be improved through the composition of the kernels (Sarkar et al., 2012). Sarkar et al. introduce a methodology to compose kernels such that the resulting system performance is improved over the sum of the performances of the individual kernels.

Flexibility in component-based development is

highly desirable in order to break the barrier of domain-specific components. In this sense, a developed design approach advertises the usage of common component platform with various plug-ins (Rothenberger et al., 2017). The advantage of the approach is that the component platform can be repurposed to meet new domains by using new plug-ins, instead of re-writing the original component platform. Similarly, the “flexible” notion that we extend in this work from component to group concept, increases the designer options when constructing a component-based system which may lead to e.g., a more efficient system.

When developing applications for heterogeneous systems, it is desirable to have code portability between CPU and GPU. To support this need, Hong et al. develop MapCG, which is a MapReduce framework that allows an efficient execution of the application, either on CPU or GPU (Hong et al., 2010). The developer writes the Map and Reduce functions and the framework generates, by source code translation, CPU and GPU versions. The MapCG run-time library executes one of the generated (CPU/GPU) version in order to increase the system performance. However, in the context of the domain targeted by our work (i.e., soft real-time and embedded systems), the MapCG run-time library does not provide the required control over the decision where to execute the application (i.e., CPU or GPU).

Regarding the generation of GPU applications, Aspect-Oriented Programming (AOP) paradigm was used to insert concerns (referred as *aspects*) into the C++ source code (Wang and Parashar, 2010). The GPU aspects, such as memory transfer activities, are inserted by a special compiler in the source code, resulting GPU applications. However, AOP does not provide the encapsulation feature that is required in the component-based development.

Besides the framework used in this work to develop GPU functionality (i.e., OpenCL), there exists other GPU programming models which are discussed in the following paragraph. CUDA⁷ is a model developed by NVIDIA to target only NVIDIA GPUs. CUDA is “*the world’s first solution for general-computing on GPUs*”⁸ but it is specific to particular GPU hardware. We mention other models such as CTM (AMD, 2006) for ATI AMD GPUs, and the academic model Brook (Buck et al., 2004).

Using OpenCL, the developer needs to handle the communication activity between the host and the device(s). This overhead is hidden by e.g., EX-

⁷<http://docs.nvidia.com/cuda/cuda-c-programming-guide/index.html>

⁸<https://developer.nvidia.com/cuda-zone>

OCHI (Wang et al., 2007) and Merge (Linderman et al., 2008) frameworks. However, employing these solutions in our work may introduce additional overhead and resource utilization which are important factors in the targeted domain (e.g., control-type, soft real-time systems).

7 Conclusions

An existing solution that provides support in development of embedded systems with GPUs is the usage of flexible components. However, its realization introduced unnecessary overheads, which we addressed in this paper through the concept of flexible groups. A flexible group encloses connected flexible components with the same hardware allocation, in a conceptual component. Furthermore, we provided an algorithm to identify the flexible groups in a given component-based system, and the generation rules that automatically realize groups as regular components. The generation rules are implemented using a state-of-the-practice component model (i.e., Rubus). The benefits of adopting our solution are examined through the vision system of an underwater robot. It is showed an improved execution time with flexible groups, compared with the existing solution.

For future directions, we consider in developing a method that automatically provides the optimized allocation of the flexible components in a given system. The method considers optimization goals important in the embedded systems domain, such as performance, memory and energy usage.

REFERENCES

- Ahlberg, C., Asplund, L., Campeanu, G., Ciccozzi, F., Ekstrand, F., Ekström, M., Feljan, J., Gustavsson, A., Sentilles, S., Svogor, I., et al. (2013). The Black Pearl: An autonomous underwater vehicle.
- AMD (2006). ATI CTM Guide - Technical Referene Manual. http://roland.pri.ee/doktor/papers/gpgpu/ATI_CTM_Guide.pdf. Accessed: 2017-10-14.
- Buck, I., Foley, T., Horn, D., Sugerma, J., Fatahalian, K., Houston, M., and Hanrahan, P. (2004). Brook for GPUs: stream computing on graphics hardware. In *ACM Transactions on Graphics (TOG)*, volume 23, pages 777–786. ACM.
- Campeanu, G., Carlson, J., and Sentilles, S. (2017). Flexible components for development of embedded systems with GPUs. In *24th Asia-Pacific Software Engineering Conference*. To appear.
- Crnkovic, I., Sentilles, S., Vulgarakis, A., and Chaudron, M. R. (2011). A classification framework for software component models. *IEEE Transactions on Software Engineering*, 37(5):593–615.
- Hänninen, K., Mäki-Turja, J., Nolin, M., Lindberg, M., Lundbäck, J., and Lundbäck, K.-L. (2008). The Rubus component model for resource constrained real-time systems. In *Industrial Embedded Systems, 2008. SIES 2008. International Symposium on*, pages 177–183. IEEE.
- Hong, C., Chen, D., Chen, W., Zheng, W., and Lin, H. (2010). MapCG: writing parallel program portable between CPU and GPU. In *Proceedings of the 19th international conference on Parallel architectures and compilation techniques*, pages 217–226. ACM.
- John, K.-H. and Tiegelkamp, M. (2010). *IEC 61131-3: Programming industrial automation systems: Concepts and programming languages, requirements for programming systems, decision-making aids*. Springer Science & Business Media.
- Lévêque, T., Carlson, J., Sentilles, S., and Borde, E. (2011). Flexible semantic-preserving flattening of hierarchical component models. In *Software Engineering and Advanced Applications (SEAA), 2011 37th EUROMICRO Conference on*, pages 31–38. IEEE.
- Linderman, M. D., Collins, J. D., Wang, H., and Meng, T. H. (2008). Merge: a programming model for heterogeneous multi-core systems. In *ACM SIGOPS operating systems review*, volume 42, pages 287–296. ACM.
- Radermacher, A., Gürcan, Ö., Cuccuru, A., Gérard, S., and Hamid, B. (2015). Split of composite components for distributed applications. In *Languages, Design Methods, and Tools for Electronic System Design*, pages 265–280. Springer.
- Rothenberger, M. A., Jain, H., and Sugumaran, V. (2017). A platform-based design approach for flexible software components. *Journal of Information Technology Theory and Application (JITTA)*, 18(2):3.
- Sarkar, S., Mitra, S., and Srinivasan, A. (2012). Reuse and refactoring of GPU kernels to design complex applications. In *Parallel and Distributed Processing with Applications (ISPA), 2012 IEEE 10th International Symposium on*, pages 134–141. IEEE.
- Sentilles, S., Vulgarakis, A., Bures, T., Carlson, J., and Crnkovic, I. (2008). A component model for control-intensive distributed embedded systems. In *CBSE*, volume 8, pages 310–317. Springer.
- Stone, J. E., Phillips, J. C., Freddolino, P. L., Hardy, D. J., Trabuco, L. G., and Schulten, K. (2007). Accelerating molecular modeling applications with graphics processors. *Journal of computational chemistry*.
- Wang, M. and Parashar, M. (2010). Object-oriented stream programming using aspects. In *Parallel & Distributed Processing (IPDPS), 2010 IEEE International Symposium on*, pages 1–11. IEEE.
- Wang, P. H., Collins, J. D., Chinya, G. N., Jiang, H., Tian, X., Girkar, M., Yang, N. Y., Lueh, G.-Y., and Wang, H. (2007). EXOCHI: architecture and programming environment for a heterogeneous multi-core multi-threaded system. In *Acm Sigplan Notices*, volume 42, pages 156–166. ACM.